

**Q1.** This question is about iron and aluminium.

(a) Iron is extracted in a blast furnace. **Figure 1** is a diagram of a blast furnace.

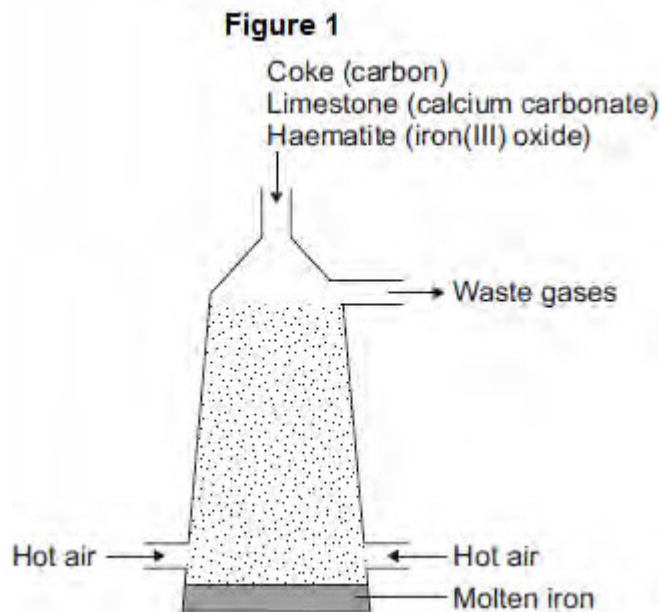

(i) Calcium carbonate decomposes at high temperatures.

Complete the word equation for the decomposition of calcium carbonate.

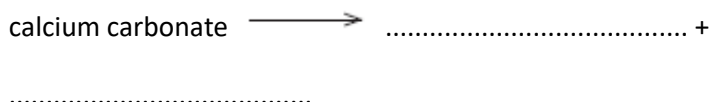

(2)

(ii) Carbon burns to produce carbon dioxide.

The carbon dioxide produced reacts with more carbon to produce carbon monoxide.

Balance the equation.



(1)

(iii) Carbon monoxide reduces iron(III) oxide:



Calculate the maximum mass of iron that can be produced from 300 tonnes of

iron(III) oxide.

Relative atomic masses ( $A_r$ ): O = 16; Fe = 56

.....

.....

.....

.....

.....

Maximum mass = ..... tonnes

(3)

- (b) Aluminium is extracted by electrolysis, as shown in **Figure 2**.

**Figure 2**

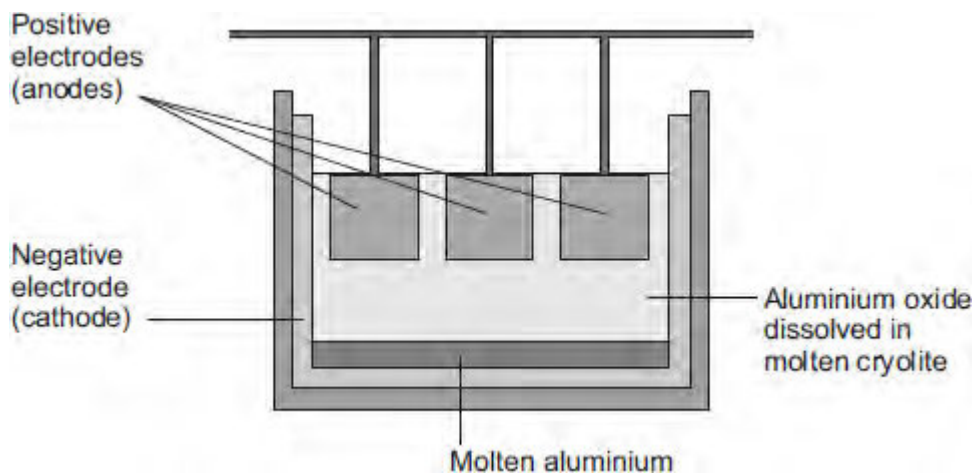

- (i) Why can aluminium **not** be extracted by heating aluminium oxide with carbon?

.....

.....

(1)

- (ii) Explain why aluminium forms at the negative electrode during electrolysis.

.....

.....  
.....  
.....  
.....  
.....  
.....

**(3)**

(iii) Explain how carbon dioxide forms at the positive electrodes during electrolysis.

.....  
.....  
.....  
.....  
.....  
.....

**(3)**

**(Total 13 marks)**

**Q2.** This question is about sodium chloride and iodine.

(a) Describe the structure and bonding in sodium chloride.

.....  
.....  
.....  
.....  
.....  
.....  
.....  
.....  
.....

**(4)**

(b) When sodium chloride solution is electrolysed, one product is chlorine.

Name the **two** other products from the electrolysis of sodium chloride solution.

.....  
.....

**(2)**

(c) Many people do not have enough iodine in their diet.

Sodium chloride is added to many types of food. Some scientists recommend that sodium chloride should have a compound of iodine added.

Give **one** ethical reason why a compound of iodine should **not** be added to sodium chloride used in food.

.....  
.....

**(1)**

(d) The bonding in iodine is similar to the bonding in chlorine.

(i) Complete the diagram below to show the bonding in iodine.

Show the outer electrons only.

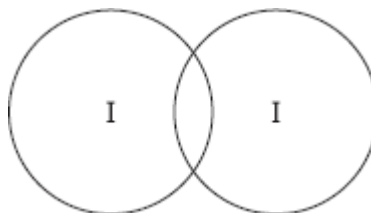

(2)

(ii) Explain why iodine has a low melting point.

.....

.....

.....

.....

.....

.....

(3)

(iii) Explain, in terms of particles, why liquid iodine does not conduct electricity.

.....

.....

.....

.....

(2)

(Total 14 marks)

**Q3.** Use the periodic table and the information in the table below to help you to answer the questions.

The table shows part of an early version of the periodic table.

Group 1	Group 2	Group 3	Group 4	Group 5	Group 6	Group 7
H						
Li	Be	B	C	N	O	F
Na	Mg	Al	Si	P	S	Cl

(a) Hydrogen was placed at the top of Group 1 in the early version of the periodic table.

The modern periodic table does **not** show hydrogen in Group 1.

(i) State one **similarity** between hydrogen and the elements in Group 1.

.....  
.....

(1)

(ii) State one **difference** between hydrogen and the elements in Group 1.

.....  
.....

(1)

(b) Fluorine, chlorine, bromine and iodine are in Group 7, the halogens.

The reactivity of the halogens decreases down the group.

Bromine reacts with a solution of potassium iodide to produce iodine.



(i) In the reaction between bromine and potassium iodide, there is a reduction of bromine to bromide ions.

In terms of electrons, what is meant by reduction?

.....

.....

(1)

(ii) Complete the half equation for the oxidation of iodide ions to iodine molecules.



(2)

(iii) Explain, in terms of electronic structure, why fluorine is the most reactive element in Group 7.

.....  
.....  
.....  
.....  
.....  
.....  
.....  
.....

(3)

(Total 8 marks)

**Q4.** Aluminium is extracted from aluminium oxide.

(a) The formula of aluminium oxide is  $\text{Al}_2\text{O}_3$

The relative formula mass ( $M_r$ ) of aluminium oxide is 102.

Calculate the percentage of aluminium in aluminium oxide.

Relative atomic masses ( $A_r$ ): O = 16; Al = 27.

.....  
.....  
.....  
.....

Percentage of aluminium = ..... %

(2)

(b) Aluminium is extracted from aluminium oxide using electrolysis.

The diagram shows a cell used for the extraction of aluminium.

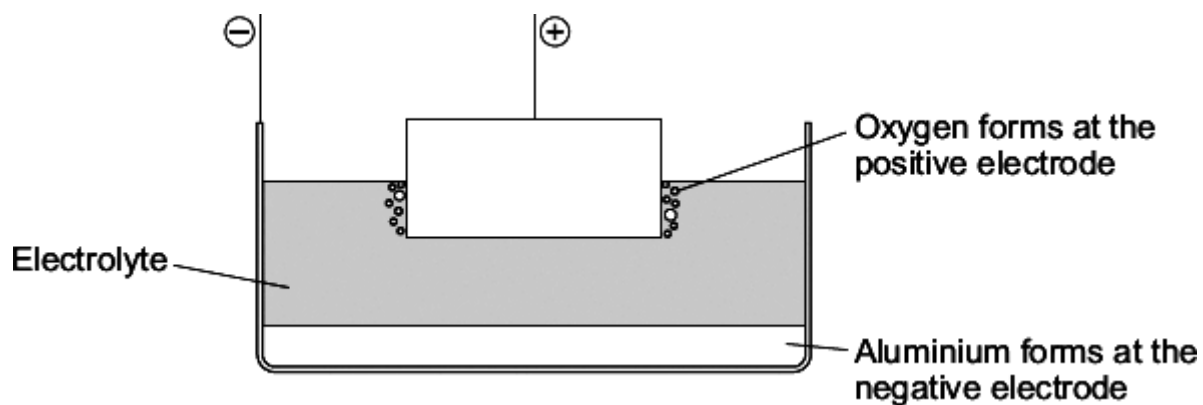

(i) The electrolyte contains cryolite.

Explain why.

.....  
.....  
.....  
.....



(2)

- (ii) Oxygen is formed at the positive electrode. Complete and balance the equation for this reaction.

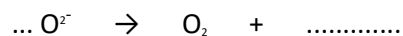

(2)

- (iii) The positive electrode in the cell is used up during the process.

Explain why.

.....

.....

.....

.....

.....

.....

(2)

(Total 8 marks)

**Q5.** Electrolysis can be used to remove unwanted hair from the skin.

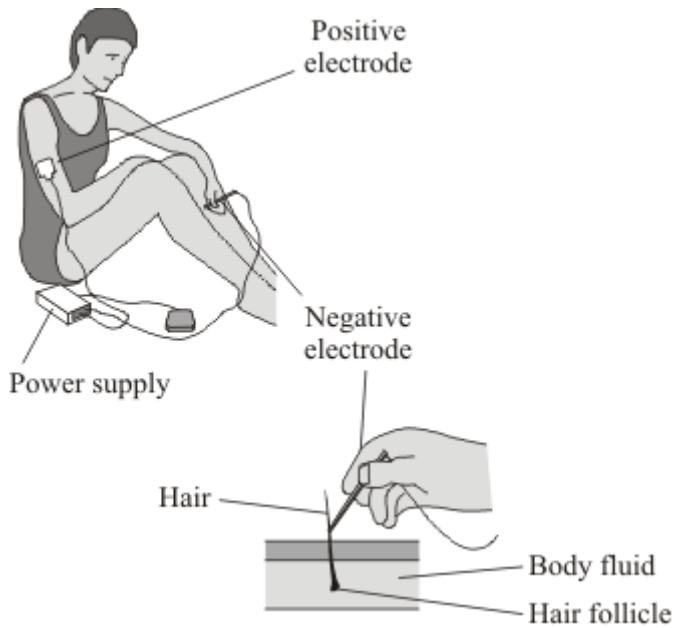

The hair is first coated with a layer of gel containing ions in solution.

The positive electrode is connected by a patch to the skin.

The negative electrode is connected to the hair. Electricity flows through the gel and causes electrolysis of the body fluid around the hair follicle.

(a) Metal wires conduct electricity to the electrodes.

Explain how metals conduct electricity.

.....  
.....  
.....  
.....

(2)

(b) Explain why the gel containing ions in solution can conduct electricity.

.....

.....

(1)

- (c) The body fluid is a solution that contains sodium chloride. The electricity causes the electrolysis of a small amount of this solution.

This solution contains hydrogen ions that move to the negative electrode.

- (i) The half equation represents the reaction at the negative electrode.

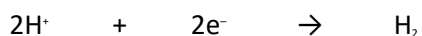

Explain why this reaction is a reduction.

.....

.....

(1)

- (ii) As a result of the electrolysis of sodium chloride solution, an alkali forms which kills the hair follicle.

What is the name of this alkali? .....

(1)

- (iii) Complete the half equation for the reaction at the positive electrode.

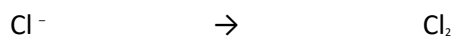

(1)

(Total 6 marks)

Q6. Read the article and then answer the questions that follow.

**Hydrogen fuel for cars?**

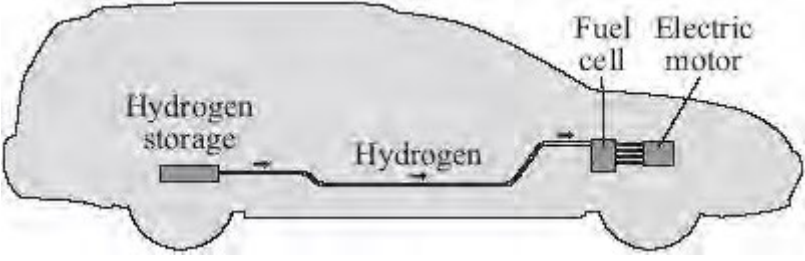

Hydrogen is an excellent fuel. It can be made by the electrolysis of potassium hydroxide solution.

Hydrogen gas can be stored under pressure in a cylinder but a leak of the gas could cause an explosion.

It has been found that lithium nitride can absorb and then release large volumes of hydrogen. A chemical reaction takes place between the hydrogen and the lithium nitride. The hydrogen is held in the resulting compounds by chemical bonds.

The problem is that the rate at which hydrogen is absorbed and then released from normal sized particles of lithium nitride is slow.

Recently scientists have made 'nanosized' particles of lithium nitride. These particles absorb hydrogen in the same way as normal sized lithium nitride particles. The 'nanosized' particles have the advantage that they absorb and release the hydrogen much faster when needed in the fuel cell.

It is hoped that 'nanosized' particles of lithium nitride may provide a safe method of storing hydrogen in the future.

(a) Hydrogen is produced at the negative electrode during the electrolysis of potassium hydroxide solution.

(i) Why are hydrogen ions attracted to the negative electrode?

.....

.....

.....

(1)

(ii) Potassium ions are also attracted to the negative electrode.

Explain why hydrogen gas is formed but not potassium.

.....  
.....  
.....

(1)

(b) Lithium nitride is made by reacting lithium with nitrogen.

Balance the equation for this reaction.

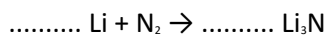

(1)

(c) (i) The equation for the reaction of lithium nitride with hydrogen is:



What feature of this reaction allows the hydrogen to be released?

.....  
.....

(1)

(ii) Hydrogen stored in a fuel tank filled with lithium nitride would be safer in an accident than a cylinder full of hydrogen.

Suggest and explain why.

.....  
.....  
.....  
.....

.....

(2)

(d) Lithium nitride is an ionic compound which contains lithium ions ( $\text{Li}^+$ ) and nitride ions ( $\text{N}^{3-}$ ).

(i) The formation of a lithium ion from a lithium atom is an oxidation reaction.

Explain why.

.....

.....

(1)

(ii) The diagram shows the electronic structure of a nitrogen atom.

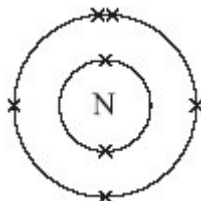

Complete the diagram below to show the electronic structure of a nitride ion ( $\text{N}^{3-}$ ).

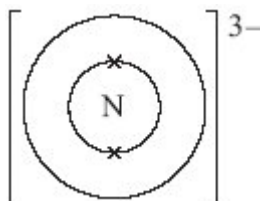

(1)

(Total 8 marks)